

GENERAL REQUIREMENTS



US EMBASSY MALABO

GENERAL REQUIREMENTS

For

Parking Lot Improvement

OCTOBER 2022

Parking Lot Improvement.

GENERAL REQUIREMENTS

The project is described as "**Parking Lot Improvement.**" The Contractor shall furnish a schedule, materials not provided by the embassy, labor, transportation, equipment, investigation, and supervision.

BACKGROUND

The increasing number of vehicles in the local employee parking creates limited parking spaces. There is a demand to improve the parking spacing to help with the overflow of vehicles.

SOLUTION

Provide trees, curb and irrigation piping removal, soil preparation, rebar and concrete works per this General Requirements and construction drawing in this document.

1. COR:

A Contracting Officer's Representative (COR) will be assigned to ensure quality assurance goals are met. The Contractor shall report to the COR on (a) the status of the project, (b) changes in Schedule, (c) accidents and safety issues, (d) disruptions to the property accessibility, and all other important information pertaining to the project.

2. Fixed-Price Proposal:

The Contractor shall provide one fixed-priced Proposal for the complete project that includes every aspect of the work. The Contractor will measure and verify the quantities needed to complete this project prior to bid submission.

The Contractor shall not incur any costs beyond those described in this SOW unless directed otherwise in writing by the Contracting Officer. Any work performed by the Contractor beyond this SOW without written direction from the Contracting Officer will be at the Contractor's own risk and at no cost to the US Embassy.

3. Design Criteria:

The work shall be governed by the drawings attached and these General Requirements.

The Contracting Officer's Representative shall provide approval for all materials and equipment prior to their use.

GENERAL REQUIREMENTS

4. Execution:

The work shall be executed in a diligent and workmanlike manner in accordance with the negotiated fixed price, this Scope of Work, and the Project Schedule.

The Contractor is responsible for preventing any damage to surrounding properties arising from the Contractor's performance of the work.

5. Work Hours:

The Contractor may work up to six days a week between the hours of 8:00 AM and 5:00 PM.

6. Safety:

The Contractor shall be responsible for conducting the work to ensure the safety of all persons at the US Embassy. Safety standards must meet current EM 385 US Corps of Engineers Safety and Health Requirements Manual requirements available online.

Prior to starting a project, the contractor is required to review the work site and identify hazards that may occur while performing the job.

Contractors shall provide each employee with personal protective equipment (PPE) to protect the employee from hazards.

The contractor is expected to provide a “competent person” to implement Site health and safety plan and to oversee its compliance. A competent person is an individual who, by way of training and/or experience, is knowledgeable of applicable standards, is capable of identifying workplace hazards relating to the specific operation, is designated by the employer, and has authority to take appropriate actions.

The contractor must place provisional barricades and warning signs to maintain a safe and accessible path-of-travel for all pedestrians, including those with disabilities, in order to avoid accidents to third parties. Barricades alert others about hazards created by construction activities and should be used to control vehicular traffic around the work site as well.

7. Workforce:

The Contractor shall be responsible for planning, monitoring, coordinating, and controlling the works. The Contractor will provide their employees with clean and complete uniforms.

GENERAL REQUIREMENTS

8. Accommodations:

The Contractor shall provide their own Porta John toilets for the jobsite. The Contractor shall also provide drinking water dispensers and maintain a supply of disposable paper cups at each dispenser.

9. Housekeeping:

The Contractor is responsible for cleaning up daily. The Contractor is responsible for disposing of all dirt, concrete, stone, and construction debris outside of the property before the close of business each day.

10. Site Security:

The Contractor shall comply with US Embassy security policy.

The Contractor shall prepare a list of all the names of personnel working for the Contractor and any subcontractors, with national ID numbers, and submit the list to the Facility Manager for vetting of employees by the RSO at least 30 days prior to commencement of work.

11. Coordination meetings:

The COR shall conduct an initial construction conference near the date of Notification to Proceed. Agenda items shall include a review of the general plans, conditions, procedures, and requirements necessary for the effective scheduling and prosecution of the construction work. Further, all parties shall review security and material delivery requirements and personnel assigned.

12. Defects in Work:

Where the Contractor has defects in the works, the Contractor shall provide corrective actions. The corrective action shall be acceptable to the COR. This does not provide a basis for a claim for Contract Modification/Additional Compensation or extension of Contract Time.

13. Work execution:

Coordinate all phases and aspects of the work carefully to achieve intended results. Upon completion of the work, return all disturbed areas to original conditions.

GENERAL REQUIREMENTS

14. General Submittals:

The Contractor shall prepare and implement an Activity Hazard Analysis (AHA) prior to the start of work for COR approval.

The Contractor is responsible for submitting a work schedule in the form of a bar chart for COR approval.

The Contractor shall provide product data for every portion of the Project for COR approval.

15. Services and Deliverables

- Removal of (4) Medians and (4) Trees
- Removal of tree roots and irrigation pipes
- Refill areas where previous medians existed with soil and compact the subgrade.
- Pour 25 MPa concrete in area where previous medians existed and install concrete curbs as shown on the drawing to match the existing parking spaces (Provide rebar grid in concrete using 12 mm rebar and 20 mm spacing)
- Relocate Gym container as shown on the drawing.
- Restripe parking lot lines.

A site visit has been scheduled for November 17, 2022, by 9am, interested firms should send their representative information (employee full name, nationality, company, phone number) to MalaboP@state.gov

16. Project Site Plan

- Existing Parking Lot Spaces

GENERAL REQUIREMENTS

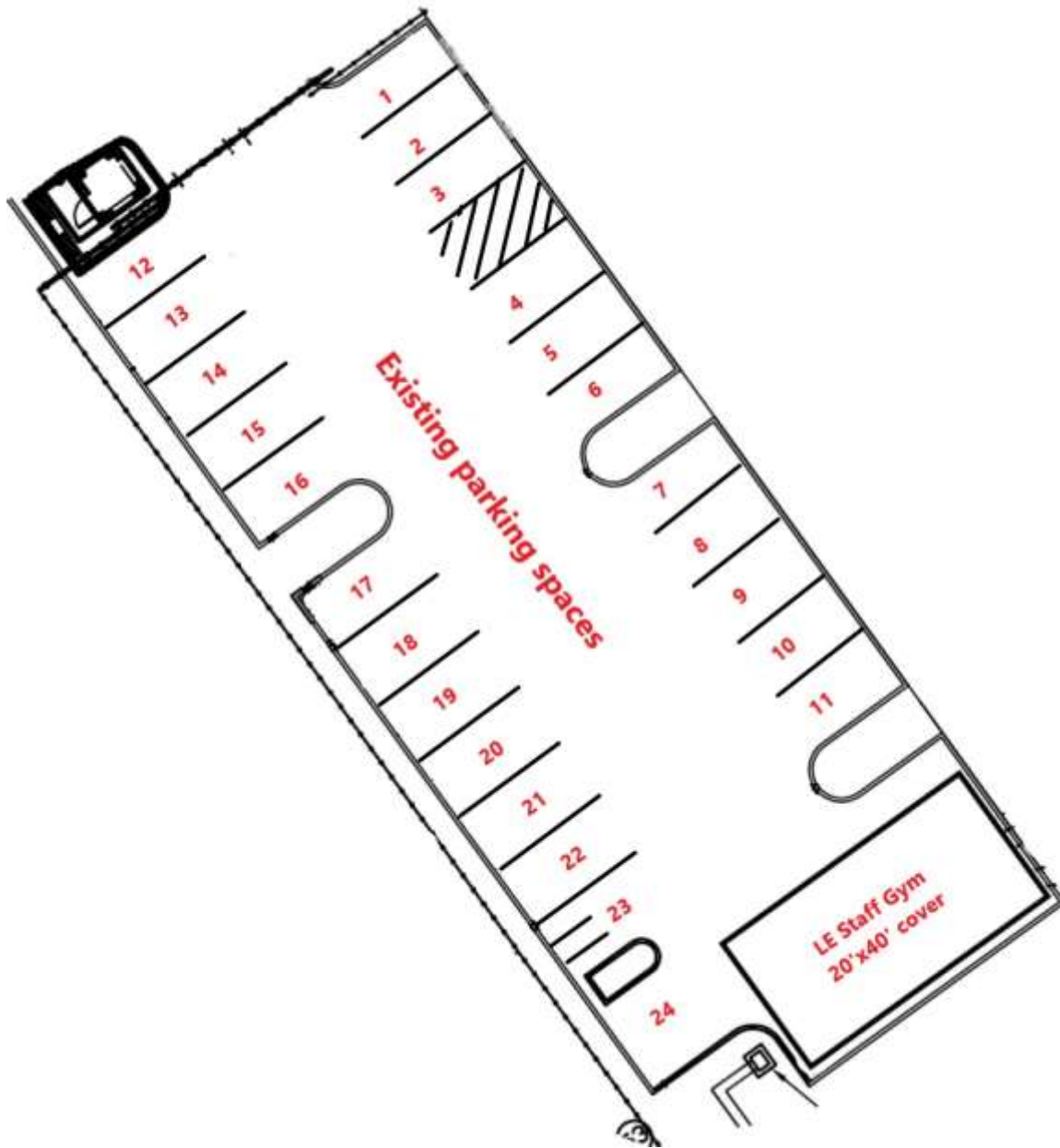

- Proposal of New Parking Lot Improvement

GENERAL REQUIREMENTS

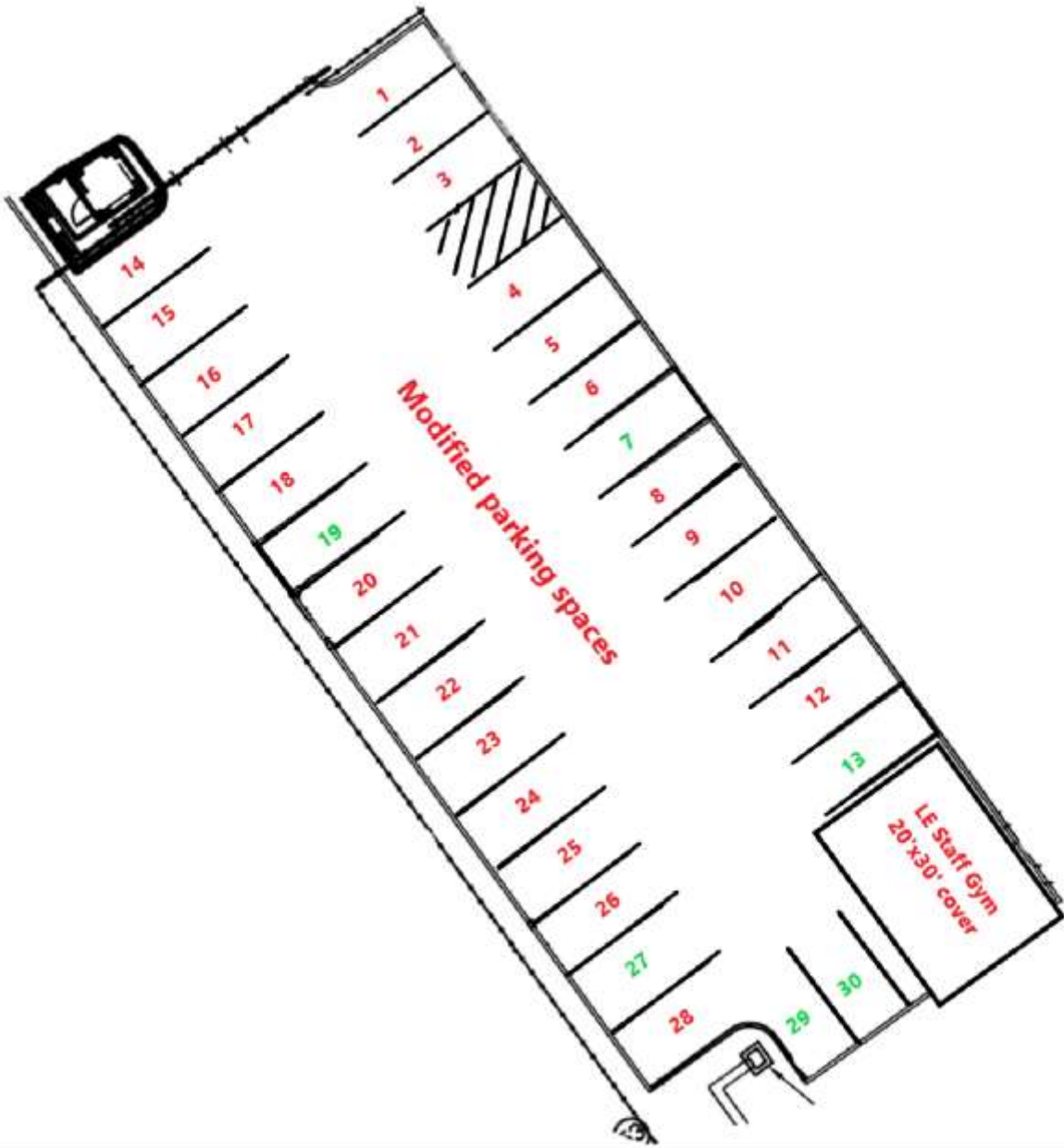

Parking Lot Improvement.

GENERAL REQUIREMENTS

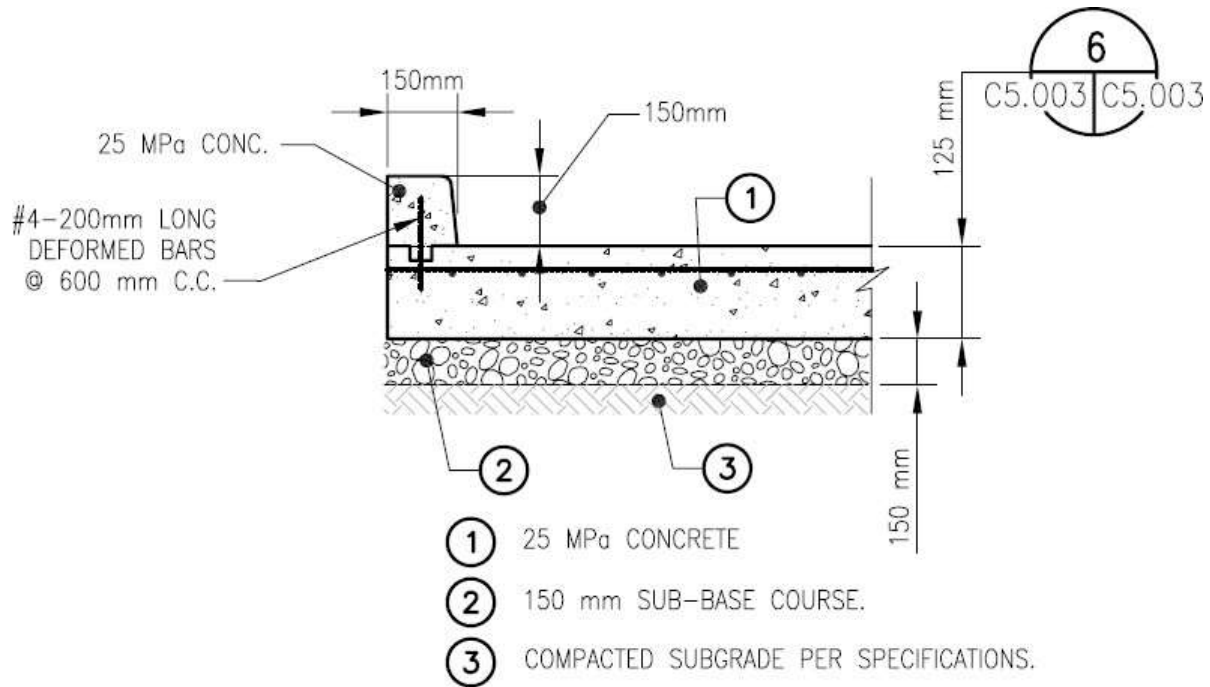

16 CONCRETE CURB AND PAVEMENT
 C1.126-29 | C5.003
 C5.004 | C5.003
 NOT TO SCALE